

MP1000EM

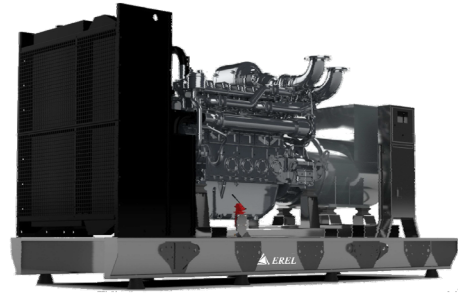

Output Rating				
Voltage	Frequency		Standby	Prime
400 V	50 Hz	KVA	1100	1000
		KW	880	800

Rating Definitions

Ratings are in accordance with ISO 8528, ISO 3046, BS 5514.

Prime Rating

Applicable for supplying continuous electrical power (no limitation to annual hours of operation), at variable load, in lieu of utility power network; 10% overload is permitted for 1 hour in every 12 hours.

Standby Rating

Applicable for supplying continuous electrical power, at variable load, in the event of a utility power failure; no overload is permitted on standby ratings.

Standard Reference Conditions

Standard reference conditions 25°C (77°F) Air Inlet Temp, 100m (328 ft) A.S.L. 30% relative humidity.

General Data	
Engine Make	MTU
Engine Model	16V2000G26F
Alternator Make	Mecc-Alte
Alternator Model	ECO43-1M4A
Control Unit	DSE 7320
Engine Speed: RPM	1500
Fuel Tank Capacity (l)	900
Fuel Consumption Standby (l/hr)	237.0
Fuel Consumption Prime (l/hr)	205.0
Fuel Consumption 75% (l/hr)	156.0
Fuel Consumption 50% (l/hr)	115.0

Optional Features and Customization

Optional Features and Customization include:

- Weather and sound proof enclosure
- Stand-alone control panel
- Synchronizing panel
- Load sharing
- Residential silencer
- CE certification
- LV Circuit Breaker

	Dimensions and Weights				
	Length (mm)	Width (mm)	Height (mm)	Weight (Kg)	
Open Set	4450	2000	2200	6600	6735
Canopied Set	TBA	TBA	TBA	TBA	TBA

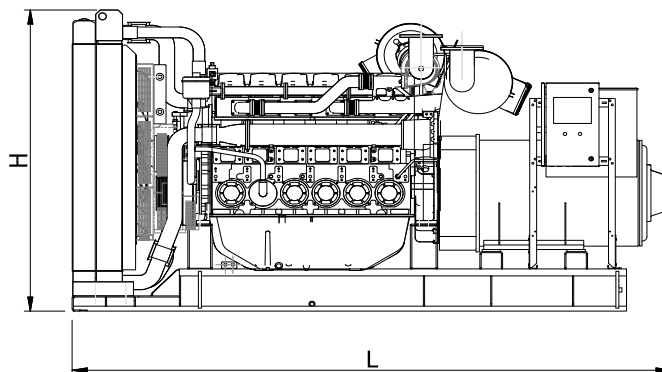
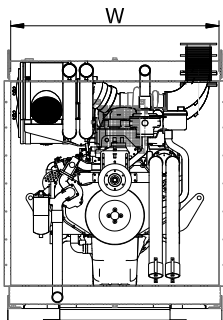

• Dimensions and weights are for guidance only. Certified drawings are available upon request. Specifications may change without notice.

MP1000EM

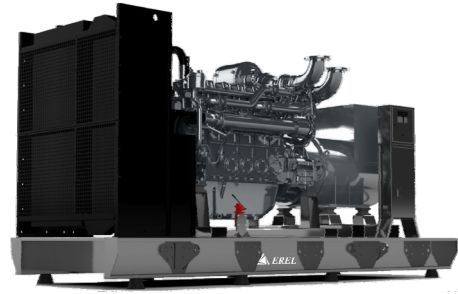

Engine Data		
Engine Model		16V2000G26F
No. of Cylinders		16
Alignment		90°V
Cycle		4-cycle
Bore	mm (in)	135 (5.3)
Stroke	mm (in)	156 (6.15)
Induction		TC-AA
Cooling Method		Water
Governing Type		Electronic
Governing Class		ECU 9
Compression Ratio		17.5
Displacement	L (cu.in)	2.23 (136)
Moment of Inertia	kg m ²	N.A.
Voltage	VDC	24
Ground		Negative
Capacity		2x75
Engine Weight Dry	Kg (lb)	3100 (6834)
Engine Weight Wet	Kg (lb)	3270 (7209)

Engine Performance Data		
Engine Speed	rpm	1500
Gross Engine Power Prime	kW (hp)	890 (1194)
Gross Engine Power Standby	kW (hp)	979 (1313)
BMEP Prime	kPa (psi)	1990 (288.6)
BMEP Standby	kPa (psi)	2190 (317.6)

Air System		
Combustion Air Flow Prime	m ³ /min	61.8
Combustion Air Flow Standby	m ³ /min	76.8
Max. Combustion Air Intake Restri	kPa	4

Alternator Physical Data		
No. of Bearings		1
Insulation Class		H
Winding Pitch		2/3
Winding Code		N.A.
Wires		N.A.
Ingress Protection Rating		IP23
Excitation System		Brushless
AVR Model		Electronic

• Dimensions and weights are for guidance only. Certified drawings are available upon request. Specifications may change without notice.

Fuel System		
Recommended Fuel		Class A2 Diesel
Fuel Consumption Prime (110%)	l/hr	237.0
Fuel Consumption Prime (100%)	l/hr	205.0
Fuel Consumption Prime (75%)	l/hr	156.0
Fuel Consumption Prime (50%)	l/hr	115.0
Fuel Consumption Standby (110%)	l/hr	N.A.
Fuel Consumption Standby (100%)	l/hr	237.0
Fuel Consumption Standby (75%)	l/hr	180.0
Fuel Consumption Standby (50%)	l/hr	124.0
Fuel Consumption Continuous	l/hr	N.A.

(Based on diesel fuel with a specific gravity of 0.86 and conforming to BS2869 classA2, EN590)

Cooling System		
Cooling System Capacity	(l)	144
Heat rejection to coolant*: Prime	kW	370
Heat rejection to coolant*: Standby	kW	375
Fan power for mech. Rad. (40°C)	kWm	43.4
Cooling air flow	m ³ /min	1462

Lubrication System		
Oil Filter Type		Replaceable elt.
Total Oil Capacity	(l)	102
Oil Pan Capacity:	(l)	N.A.
Oil Type		SAE 15W40
Oil Cooling Method		Water

Exhaust System		
Maximum Allowable Back Pressur	kPa	5
Exhaust Gas Flow: Prime	m ³ /min	167
Exhaust Gas Flow: Standby	m ³ /min	201
Exhaust Gas T°: Prime	°C	515
Exhaust Gas T°: Standby	°C	530

Alternator Operating Data		
Overspeed	rpm	2250
Voltage Regulation: (Steady state)	%	±0.25
Wave Form NEMA = TIF		50
Wave Form IEC = THF	%	2
Total Harmonic content LL/LN	%	N.A.
Radio Interference		EN61000-6
Radiant Heat: 50 Hz	kW	N.A.