

MP650EM

Output Rating

Voltage	Frequency		Standby	Prime
400 V	50 Hz	KVA	728	662
		KW	582	530

Rating Definitions

Ratings are in accordance with ISO 8528, ISO 3046, BS 5514.

Prime Rating

Applicable for supplying continuous electrical power (no limitation to annual hours of operation), at variable load, in lieu of utility power network; 10% overload is permitted for 1 hour in every 12 hours.

Standby Rating

Applicable for supplying continuous electrical power, at variable load, in the event of a utility power failure; no overload is permitted on standby ratings.

Standard Reference Conditions

Standard reference conditions 25°C (77°F) Air Inlet Temp, 100m (328 ft) A.S.L. 30% relative humidity.

General Data

Engine Make	MTU
Engine Model	12V1600G20F
Alternator Make	Mecc-Alte
Alternator Model	ECO40-2L4B
Control Unit	DSE 7320
Engine Speed: RPM	1500
Fuel Tank Capacity (l)	750
Fuel Consumption Standby (l/hr)	141.5
Fuel Consumption Prime (l/hr)	128.6
Fuel Consumption 75% (l/hr)	99.0
Fuel Consumption 50% (l/hr)	69.0

Optional Features and Customization

Optional Features and Customization include:

- Weather and sound proof enclosure
- Stand-alone control panel
- Synchronizing panel
- Load sharing
- Residential silencer
- CE certification
- LV Circuit Breaker

Dimensions and Weights

	Length (mm)	Width (mm)	Height (mm)	Weight (Kg)	
				Dry	Wet
Open Set	3600	1600	2125	4700	4850
Canopied Set	TBA	TBA	TBA	TBA	TBA

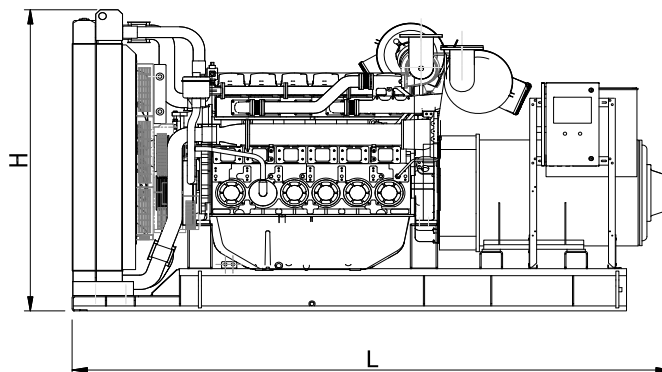
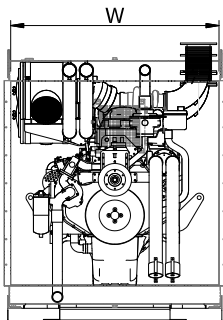

• Dimensions and weights are for guidance only. Certified drawings are available upon request. Specifications may change without notice.

MP650EM

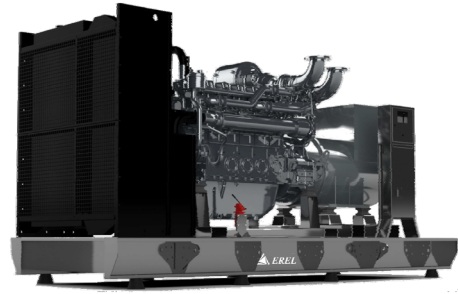

Engine Data		
Engine Model		12V1600G20F
No. of Cylinders		12
Alignment		90°V
Cycle		4-cycle
Bore	mm (in)	122 (4.8)
Stroke	mm (in)	150 (5.9)
Induction		TC
Cooling Method		Water
Governing Type		Electronic
Governing Class		ECU 8
Compression Ratio		17.5
Displacement	L (cu.in)	1.75 (107)
Moment of Inertia	kg m ²	N.A.
Voltage	VDC	24
Ground		Negative
Capacity	AH	2x75
Engine Weight Dry	Kg (lb)	1855 (3735)
Engine Weight Wet	Kg (lb)	2025 (4464)

Engine Performance Data		
Engine Speed	rpm	1500
Gross Engine Power Prime	kW (hp)	576 (772)
Gross Engine Power Standby	kW (hp)	634 (850)
BMEP Prime	kPa (psi)	N.A.
BMEP Standby	kPa (psi)	N.A.

Air System		
Combustion Air Flow Prime	m ³ /min	48
Combustion Air Flow Standby	m ³ /min	45
Max. Combustion Air Intake Restri	kPa	N.A.

Alternator Physical Data		
No. of Bearings		1
Insulation Class		H
Winding Pitch		2/3
Winding Code		N.A.
Wires		N.A.
Ingress Protection Rating		IP23
Excitation System		Brushless
AVR Model		Electronic

• Dimensions and weights are for guidance only. Certified drawings are available upon request. Specifications may change without notice.

Fuel System		
Recommended Fuel		Class A2 Diesel
Fuel Consumption Prime (110%)	l/hr	141.5
Fuel Consumption Prime (100%)	l/hr	128.6
Fuel Consumption Prime (75%)	l/hr	99.0
Fuel Consumption Prime (50%)	l/hr	69.0
Fuel Consumption Standby (110%)	l/hr	N.A.
Fuel Consumption Standby (100%)	l/hr	141.5
Fuel Consumption Standby (75%)	l/hr	N.A.
Fuel Consumption Standby (50%)	l/hr	N.A.
Fuel Consumption Continuous	l/hr	N.A.

(Based on diesel fuel with a specific gravity of 0.86 and conforming to BS2869 classA2, EN590)

Cooling System		
Cooling System Capacity	(l)	99
Heat rejection to coolant*: Prime	kW	236
Heat rejection to coolant*: Standby	kW	255
Fan power for mech. Rad. (40°C)	kWm	N.A.
Cooling air flow	m ³ /s	702

Lubrication System		
Oil Filter Type		Replaceable elt.
Total Oil Capacity	(l)	72.5
Oil Pan Capacity:	(l)	80
Oil Type		SAE 15W40
Oil Cooling Method		Water

Exhaust System		
Maximum Allowable Back Pressur	kPa	15
Exhaust Gas Flow: Prime	m ³ /min	126
Exhaust Gas Flow: Standby	m ³ /min	120
Exhaust Gas T°: Prime	°C	485
Exhaust Gas T°: Standby	°C	485

Alternator Operating Data		
Overspeed	rpm	2250
Voltage Regulation: (Steady state)	%	±0.25
Wave Form NEMA = TIF		50
Wave Form IEC = THF	%	2
Total Harmonic content LL/LN	%	N.A.
Radio Interference		EN61000-6
Radiant Heat: 50 Hz	kW	N.A.